

SETP series eccentric screw pumps for vertical installation

Applications

For pumping neutral or corrosive liquids, uncontaminated or abrasive liquids, liquids containing gases or which tend to froth, and liquids of high or low viscosity, including liquids containing fibrous and solid material.

Principal fields of application

Waste water and waste water treatment engineering, the chemical and petrochemical industries, the paper and cellulose industries, the soap and fats industry, the paint industry, the food and drinks industry, plastics industry, ceramics, agriculture, the sugar industry, shipbuilding etc.

Operation

Rotary self-priming, positive displacement pumps whose pumping elements are formed by a rotating eccentric screw (the rotor) and a fixed stator. In any cross-sectional plane, the elements are in contact with one another at two points and along the length of the elements these points form two lines of seal. The material contained in the sealed enclosed cavities which are formed as the rotor turns is displaced axially and with complete continuity from the suction to the delivery end of the pump. Despite the fact that the rotor rotates, no turbulence is produced. The constant volume of the enclosed cavities means that there are no pressurising forces and thus guarantees a low surge pumping action which is not at all severe on the material being pumped.

Design features

The discharge casing, stator and suction cover are held together by external tie rods.

The stator, which is vulcanized into a tubular casing or a cast casing (uniform rubber wall thickness), is provided at both ends with external collars vulcanized to it, which provide a safe seal from the suction cover and discharge casing.

With stainless steel versions, the stator is also protected against external corrosion by a separate, sealed stator casing (with other materials available at extra charge).

The sizes 2700 and 5000 always have a stator of uniform rubber wall thickness.

For all pump sizes, the suction cover is designed in such a way that an inlet strainer can be added or a steady bracket (with/without inlet strainer) can be provided for the suction side of the pump (accessories available at extra charge).

Between the discharge casing and the bearing housing is situated an interchangeable housing for a stuffing box or mechanical seal (pumps can be converted retrospectively to a different type of seal).

The drive shaft is carried in bearings in the bearing housing. The drive torque is transmitted to the rotor via the drive shaft and the coupling rod. The coupling rod terminates at both ends in universal joints which are encapsulated to form a liquid tight seal. These pin-type universal joints are of particularly simple and rugged design and are able to withstand the eccentric movement of the rotor without any difficulty.

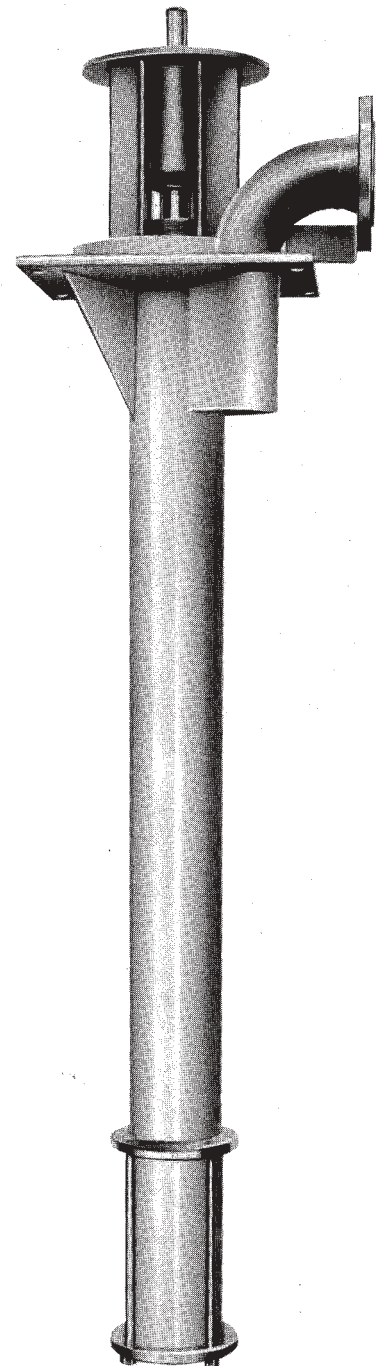

The standard installation depths and mounting flanges given in the table of dimensions (page 9) can be adapted to suit the customer's requirements in special cases.

Shaft seals/Shaft wear sleeves

Shafts are sealed by cooled or uncooled stuffing boxes or cooled or uncooled, non-balanced single or double-acting mechanical seals which require no maintenance.

The type of seal and the material pairings are adapted to suit the particular operating conditions which exist in any given case.

For further details see Page 5.

In any given size of pump, the housings for the various types of stuffing box or mechanical seal are interchangeable with one another. The various parts of the housings for mechanical seals form a modular system and can be combined with one another without any difficulty should the pump be converted to a different type of mechanical seal.

With all the types of seal the shaft can be supplied with or without a shaft wear sleeve at the point where the shaft seal is situated. For a given size of pump, one sleeve is used for all types of stuffing box and one sleeve for all types of mechanical seal.

Where shafts are fitted with shaft wear sleeves, a conversion from a stuffing box to a mechanical seal can easily be made by replacing the shaft wear sleeve and shaft sleeve and the seal housing without the need to modify the drive shaft.

Mechanical seals to DIN 24 960 can be fitted.

For further details see pages 5, 6 and 7.

Leakage from the seal area is collected in a drip pan and can be drained externally or into the pump sump/reservoir.

Bearings

The drive shaft is carried in particularly rugged bearings. The bearings are situated in the bearing housing and consist of one radial bearing (a deep-groove ball-bearing) and one thrust bearing (a double-row angular contact ball-bearing) which are individually repackable.

For further details, see pages 4 and 6.

Replaceability of parts

The components for all our eccentric screw pumps are produced to a modular system. It is thus simple and inexpensive to maintain a stock of spares even where pumps of different designs belonging to different series are used in one and the same installation.

Installation

SETP pumps are installed vertically. The pump and driver are connected together via a flexible coupling and motor lantern or via an intermediate transmission (e.g. V-belt drive).

Depending on the installation depth and pump speed, it may be necessary to fit a steady bracket for suction-end guidance of the pump. It is designed to suit the structural conditions. Dimensions of assemblies available on request.

Drivers

For possible types of drive see page 11.

Drivers produced by any manufacturer can be used. Technical characteristics and dimensions should be taken from the documentation issued by the manufacturer.

Technical characteristics

The output and drive powers required can be taken from the selection chart on page 3 or from the individual pump characteristics.

See table below for maximum pump speeds with reference to pump size and installation depth.

Permissible casing pressure	10 bar ①
Maximum delivery pressure	
Single stage, sizes 50 to 1450	6 bar
sizes 2700 to 5000	8 bar ①
size 9500	②
Two stage	10 bar ①
Suction obtainable	0.95 bar ③
Maximum permitted temperature for liquid pumped	150 °C ④
Maximum permissible viscosity	300 000 mPa s ⑤
Maximum permissible solid content	60 % by volume ⑥

Vertically installed pumps for higher delivery pressures on request.

Maximum permitted grain sizes and fibre lengths:

Pump size	50	100	200	380	550	750
Max. grain size in mm	3	3.8	5	6.8	6.8	9.5
Max. fibre length in mm	42	48	60	79	79	98

Pump size	1000	1450	2700	5000	9500
Max. grain size in mm	9.5	14	20	25	②
Max. fibre length in mm	98	130	210	250	②

Reference table for maximum pump speeds (rpm) depending on pump size and installation depth:

		Installation depth T (mm)									
		800	1200	1600	2000	2400	2800	3200	3600	4000	
		Max. pump speed (rpm) ⑦									
Pump size	50	850	850	850	850	830	720	620	530	460	
	100	700	700	700	680	580	510	440	380	320	
	200	-	600	550	480	410	360	310	270	230	
	380	-	480	410	360	310	270	230	200	170	
	550	-	-	-	-	-	-	-	-	-	-
	750	-	330	280	250	210	185	160	140	120	
	1000	-	-	200	180	150	130	115	100	85	
	1450	-	-	150	130	110	100	90	80	70	
	2700	-	-	-	100	90	80	70	60	55	
5000	-	-	-	-	-	-	-	-	-	-	
9500	②										

① Note also the permitted pressure for the shaft seal (see pages 6 and 7).

② On request.

③ Depending on operating conditions and number of stages.

④ Depending on the liquid being pumped and the elastomers used. Operating limits for cooling or heating of shaft seal available on request. For permitted pressures and temperatures of heating and cooling liquid, see page 10.

⑤ Depending on liquid being pumped, speed and pump size.

⑥ Depending on pump size and nature and size of solids.

⑦ Depending on site conditions, reduction may be necessary. When using steady brackets, higher speeds are possible in some cases (manufacturer must be consulted).

Performance Chart

To give a rough indication of the appropriate pump size and speed as a function of the required output and the nature of the liquid to be pumped. $vg_{,m}$ = mean rubbing speed of rotor in stator.

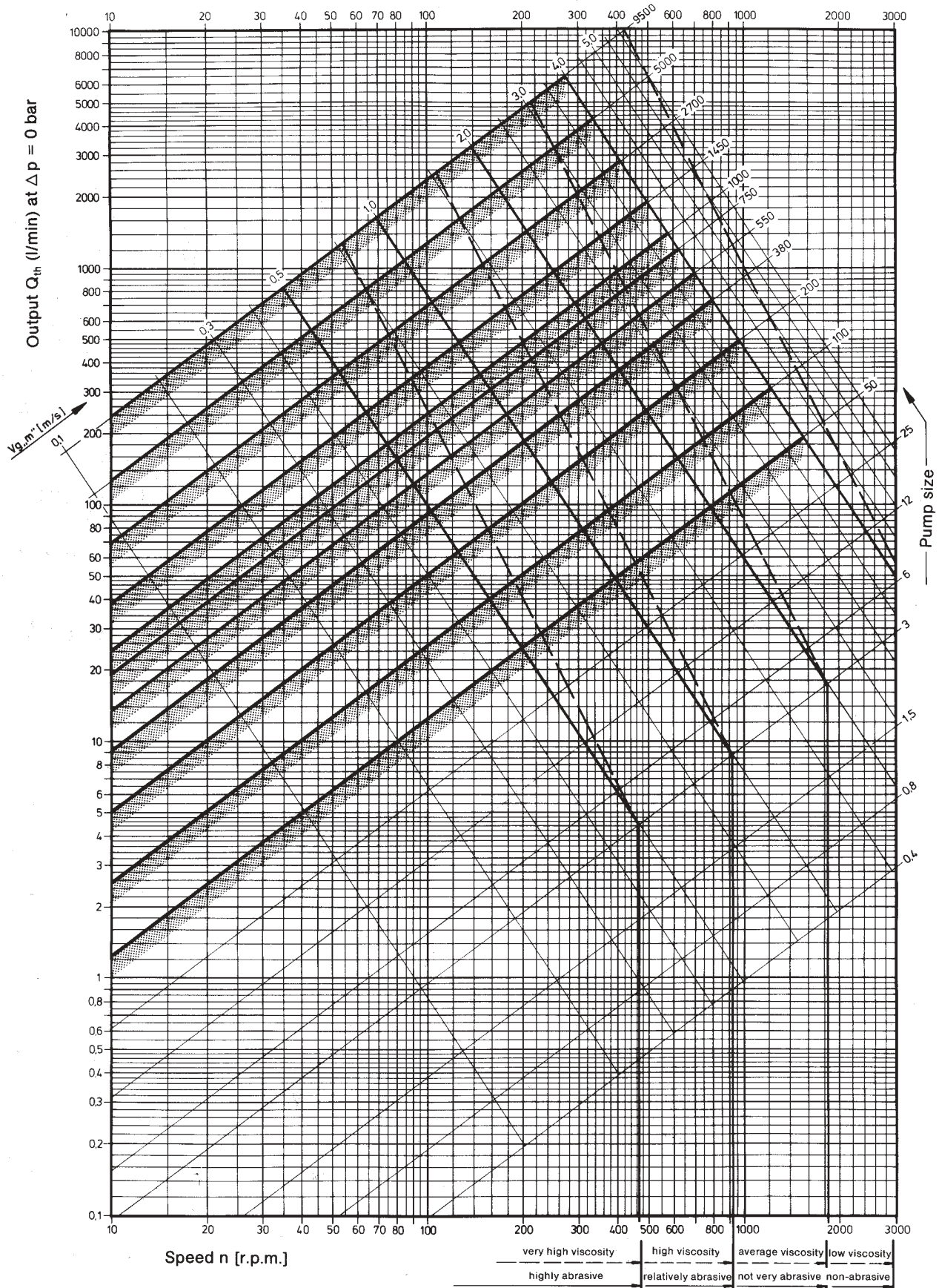

Sizes in SETP Series. Information on performance ranges not covered by the SETP Series can be found on the back cover of this brochure or in the separate brochures dealing with the other series. For exact performance data, see the individual pump characteristics.

Type coding

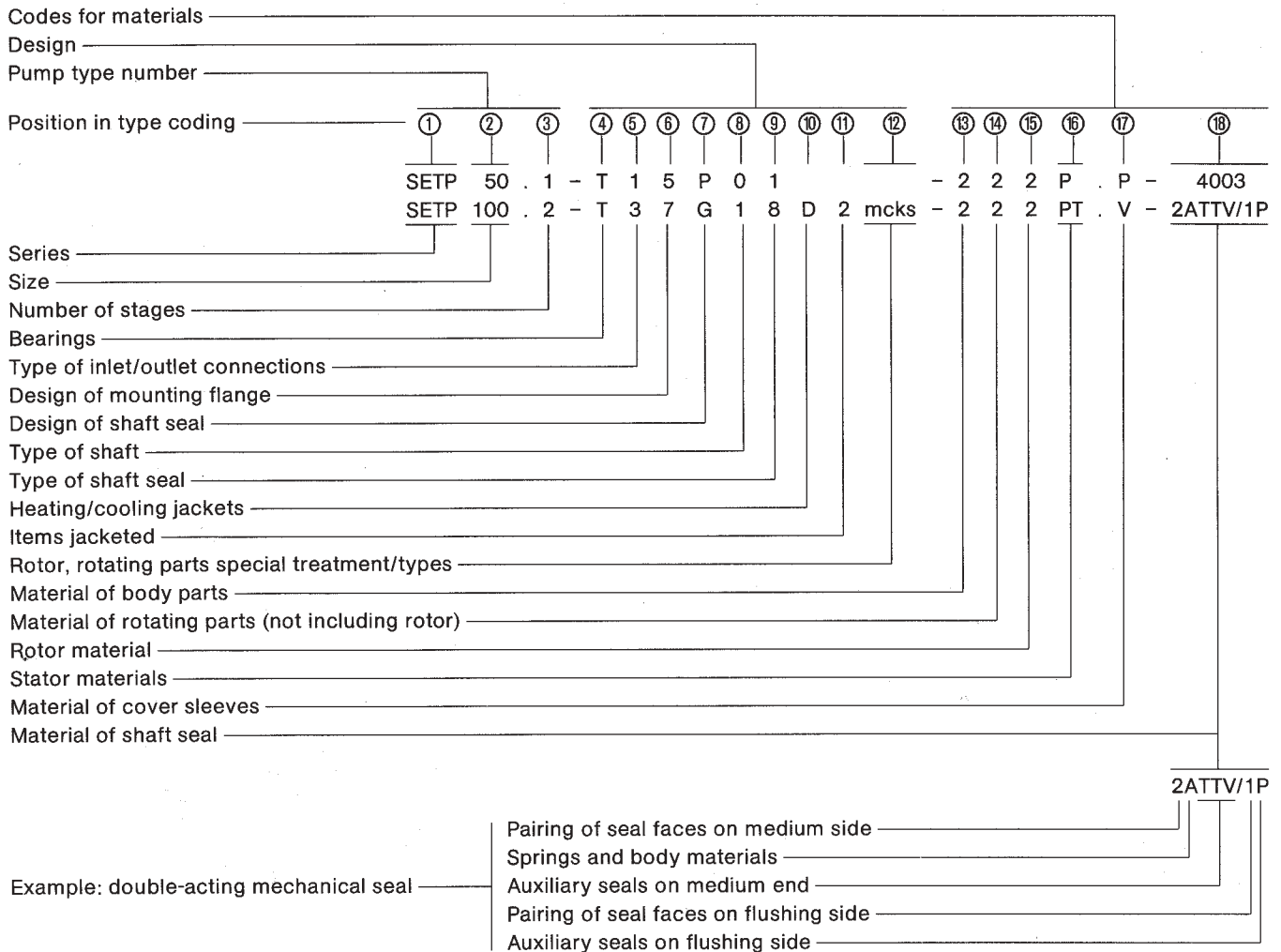

Explanatory notes on the type coding:

Position in type coding	Name	Explanation
①	Series	ALLWEILER eccentric screw pump
②	Size	Possible sizes: 50, 100, 200, 380, 550, 750, 1000, 1450, 2700, 5000, 9500 The numbers indicate the theoretical output in l/min. at n = 400 r.p.m. and Δp = 0 bar
③	Number of stages	1 = Single-stage up to 6 bar (size 50 to 1450); up to 8 bar (size 2700 and 5000) 2 = Two-stage up to 10 bar (sizes 550, 1000, 2700, 5000 and 9500 only available as single-stage pumps)
④	Bearings	T = Radial bearing with sealing cover on pump side and lip seal on drive side. Axial bearing with lip seal on pump side and grease quantity controller on drive side. Both bearings are regreaseable X = Special-type bearings
⑤	Type of outlet connections	1 = DIN-Flanges 3 = ANSI-Flanges X = Special Type Flanges } Acc. to Dimensional Drawing
⑥	Design of mounting flange	5 = Standard, squared 6 = Small, squared 7 = circular X = Special type mounting flange (e.g. with machined contact surface) } without machined contact surface acc. to dimensional drawing on page 8 and 9
⑦	Type of shaft seal	P = Stuffing box or other non-mechanical shaft seal G = Mechanical seal
⑧	Design of shaft seal	0 = No wear sleeve on shaft (special execution) 1 = Shaft fitted with wear sleeve

9	Type of shaft seal	<p>P. 1 = Standard stuffing box (no lantern ring / no flushing ring) P. 2 = Stuffing box with flushing ring P. 3 = Stuffing box with internal lantern ring P. 4 = Stuffing box with external lantern ring P. X = Special type of non-mechanical shaft seal G. 0 = Mechanical seal, single acting, non-balanced, either direction of rotation, single spring, elastomer O-rings¹⁾ G. 1 = As for G.0 but with multiple springs¹⁾ G. 2 = As for G.0 but O-rings with double PTFE sheathing¹⁾ G. 3 = As for G.1 but O-rings with double PTFE sheathing¹⁾ G. 4 = As for G.0 but with throttled outlet for flushing liquid into pump chamber G. 5 = As for G.4 but with multiple springs G. 6 = As for G.4 but O-rings with double PTFE sheathing G. 7 = As for G.5 but O-rings with double PTFE sheathing G. 8 = Mechanical seal, double-acting, non-balanced, either direction of rotation, with multiple springs, all O-rings of elastomer or O-rings on medium side with double PTFE sheathing and elastomer O-rings on flushing liquid side G. 9 = As for G.8 but all O-rings with double PTFE sheathing G. X = Special-type mechanical seal</p> <p>1) with vent line to outlet connection, only for shaft seal design G.0, G.1, G.2, G.3</p>											
10	Heating/cooling jacket	D = Jacket for heating or cooling											
11	Items jacketed	2 = Stuffing box housing X = Special version for extra jacketing											
12	Rotor/rotating parts special treatment/types	m = Rotor with moderate thermal expansion clearance (standard stator) h = Rotor with high thermal expansion clearance (standard stator) e = Rotor with moderate thermal expansion clearance (stator with uniform rubber wall thickness) f = Rotor with high thermal expansion clearance (stator with uniform rubber wall thickness) c = Hard-chromed rotor k = Shaft or shaft wear sleeve ceramic coated s = Auger on coupling rod w = Coupling rod with large diameter sleeve (to minimise rag build-up) g = Stator with uniform rubber wall thickness x = Other types											
13	Material of body parts	1 = St35/St37 2 = 1.4301	4 = 1.4571 x = Special material										
14	Material of rotating parts (not including rotor)	1 = 1.4021 / 1.4301 2 = 1.4301 4 = 1.4571	x = Special materials, e.g. also for joint components										
15	Rotor material	2 = 1.4301 3 = 1.2436	4 = 1.4571 x = Special materials, e.g. other metals, plastics										
16	Stator material	W = Soft natural rubber P = Perbunan N L = Light-coloured Perbunan N = Neoprene Y = Hypalon	V = Viton B = Butyl rubber T = Thiokol VU = Vulkollan PA = Polyamide PP = Polypropylene PT = PTFE reinforced ME = Cast Meehanite X = Special materials, e.g. metal plastics, elastomers										
17	Material of universal joint sleeves	P = Perbunan N L = Light-coloured Perbunan N = Neoprene	Y = Hypalon V = Viton B = Butyl rubber T = Thiokol O = No sleeves fitted X = Special materials										
18	Materials of shaft seal	<p>Stuffing boxes: 3207 mo = White asbestos packing, molycolated 4003 = Light-coloured cotton packing, tallowed 3207 mol = Oil packing 3235 = PTFE/white asbestos packing 3326/D/SA = PTFE/blue asbestos packing, solvent packing 6426 = Araflon packing X = Other packing materials</p> <p>Mechanical seals:</p> <table border="1" data-bbox="440 1696 1472 2041"> <thead> <tr> <th data-bbox="440 1696 841 1738">Seal faces</th> <th data-bbox="841 1696 1143 1738">Springs and body materials</th> <th data-bbox="1143 1696 1472 1738">Auxiliary seals</th> </tr> </thead> <tbody> <tr> <td data-bbox="440 1738 841 1801">1st figure with single seals 1st and 4th figures with double seals</td> <td data-bbox="841 1738 1143 1801">2nd figure</td> <td data-bbox="1143 1738 1472 1801">3rd figure with single seals, 3rd and 5th figure with double seals</td> </tr> <tr> <td data-bbox="440 1801 841 2041"> 1 = Cast Cr steel/hard carbon 2 = Cast CrMo steel/hard carbon 3 = Armoured CrNiMo steel/hard carbon 4 = Ceramic/hard carbon 5 = Carbide/Carbide highly wear-resistant 6 = Carbide/Carbide corrosion resistant 7 = Carbide/Carbide highly corrosion resistant x = Special materials </td> <td data-bbox="841 1801 1143 2041"> A = 1.4300 F = 1.4571 L = Hastelloy B M = Hastelloy C X = Special materials ① With double </td> <td data-bbox="1143 1801 1472 2041"> P = Perbunan E = EP rubber S = Silicone rubber N = Neoprene V = Viton TTE = EP rubber ① TTV = Viton ① TTS = Silicone rubber ① X = Special materials </td> </tr> </tbody> </table>			Seal faces	Springs and body materials	Auxiliary seals	1st figure with single seals 1st and 4th figures with double seals	2nd figure	3rd figure with single seals, 3rd and 5th figure with double seals	1 = Cast Cr steel/hard carbon 2 = Cast CrMo steel/hard carbon 3 = Armoured CrNiMo steel/hard carbon 4 = Ceramic/hard carbon 5 = Carbide/Carbide highly wear-resistant 6 = Carbide/Carbide corrosion resistant 7 = Carbide/Carbide highly corrosion resistant x = Special materials	A = 1.4300 F = 1.4571 L = Hastelloy B M = Hastelloy C X = Special materials ① With double	P = Perbunan E = EP rubber S = Silicone rubber N = Neoprene V = Viton TTE = EP rubber ① TTV = Viton ① TTS = Silicone rubber ① X = Special materials
Seal faces	Springs and body materials	Auxiliary seals											
1st figure with single seals 1st and 4th figures with double seals	2nd figure	3rd figure with single seals, 3rd and 5th figure with double seals											
1 = Cast Cr steel/hard carbon 2 = Cast CrMo steel/hard carbon 3 = Armoured CrNiMo steel/hard carbon 4 = Ceramic/hard carbon 5 = Carbide/Carbide highly wear-resistant 6 = Carbide/Carbide corrosion resistant 7 = Carbide/Carbide highly corrosion resistant x = Special materials	A = 1.4300 F = 1.4571 L = Hastelloy B M = Hastelloy C X = Special materials ① With double	P = Perbunan E = EP rubber S = Silicone rubber N = Neoprene V = Viton TTE = EP rubber ① TTV = Viton ① TTS = Silicone rubber ① X = Special materials											

Sectional drawing and parts list

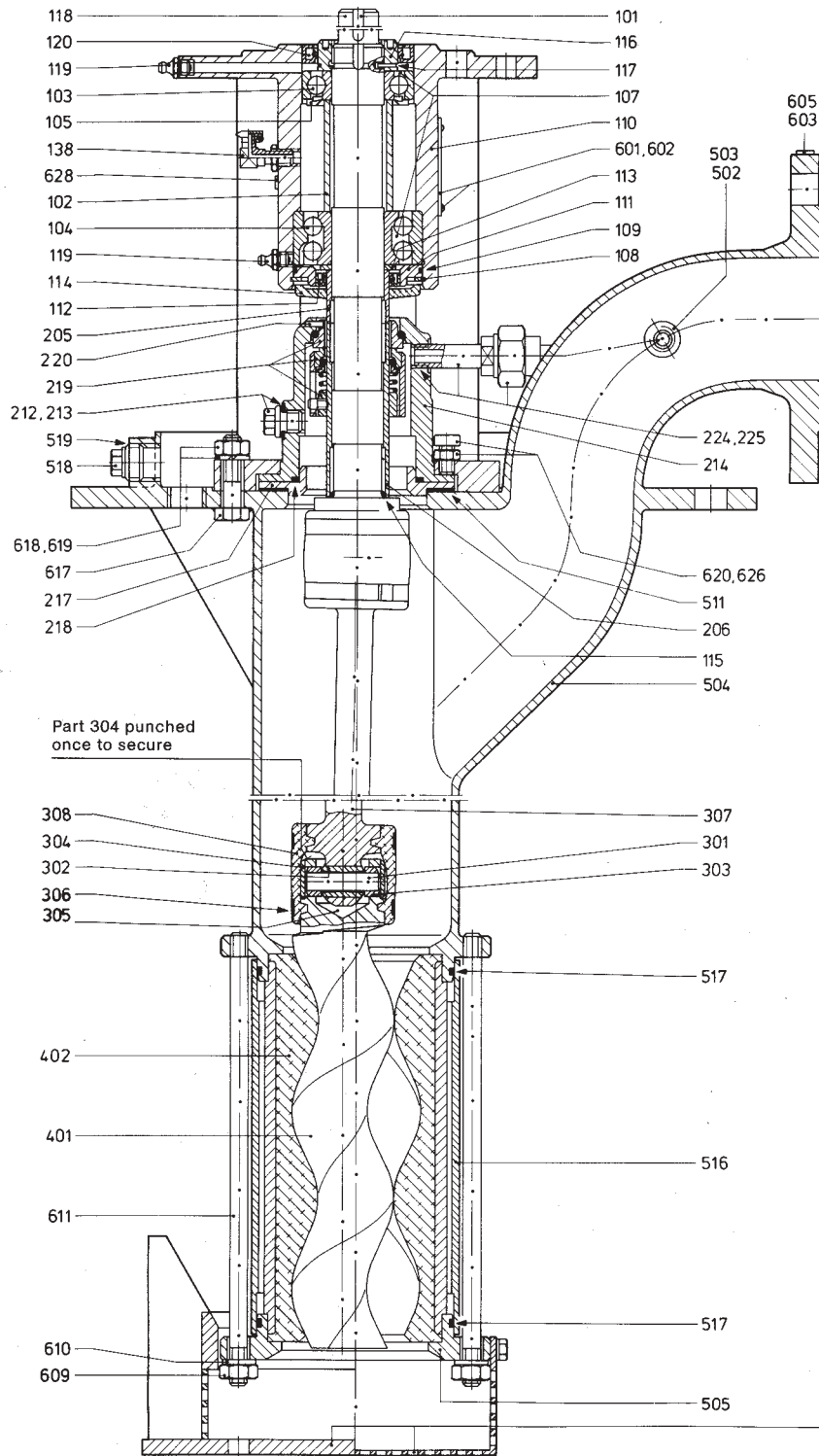

Bearings: T (repackable)

Shaft seal:

G10 to G13 Mechanical seal, single acting, non-balanced, either direction of rotation, with shaft wear sleeve (type G12 shown in drawing). With vent line to outlet connection ④

G00 to G03 as **G10 to G13** but without shaft wear sleeve. For pressures up to 10 bar Consult manufacturer

Coarse strainer or steady bracket (with/without coarse strainer) optional available against extra charge.

Part No.	Description	Part No.	Description	Part No.	Description
101	Key	117	Tab washer for bearing nut	213	Sealing ring
102	Spacer sleeve	118	Drive shaft	214	Mechanical seal housing
103	Radial bearing	119	Grease nipple	215	Mechanical seal cover
104	Axial bearing	120	Lip-seal, drive side	216	Clamping ring
105	Nilos ring	138	Grease quantity controller	217	Locating ring
107	Bearing grease	201	T-head bolt	218	O-ring
108	Retaining circlip	202	Self-locking nut	219	Mechanical seal
109	O-ring	203	Packing gland	220 ②	Retaining pin
110	Bearing housing	204	Stuffing box housing	224 ④	Vent line for mechanical seal
111	Bearing cover	205 ①	Shaft sleeve	225 ④	Sealing compound
112	Lip seal, pump side	206 ①	Shaft wear sleeve	301	Coupling rod pin
113	Spacer ring	207	Stuffing box packing	302	Coupling rod bush
114	Flinger ring	208	Flushing ring	303	Guide bush
115 ①	O-ring	209	Lantern ring	304	Retaining sleeve
116	Bearing nut	212	Screwed plug	305	Joint grease

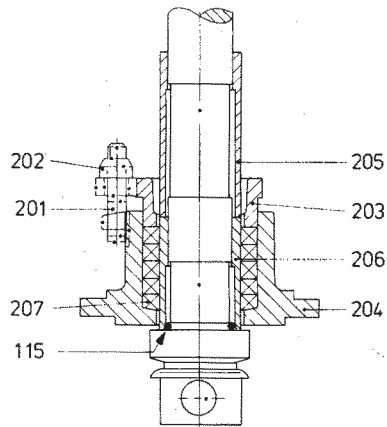

P11 Stuffing box of standard type (no lantern ring/no flushing ring) with shaft wear sleeve.
P01 as P11, but without shaft wear sleeve.
 Particularly long packing allows pump to be used in a wide variety of applications. Permitted pressure at shaft seal $p = \text{up to } 4.0 \text{ bar}$.

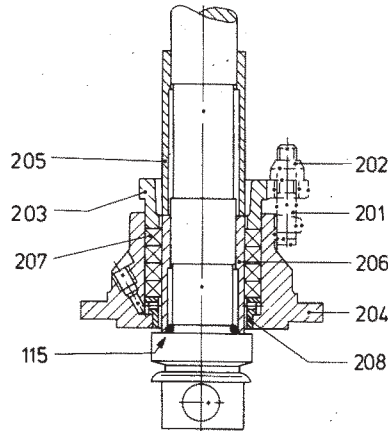

P12 Stuffing box with shaft wear sleeve and flushing ring.
P02 as P12, but without shaft wear sleeve ①.
 Suitable for highly abrasive pumped liquids with external flushing.
 $p = \text{up to } 4.0 \text{ bar}$.

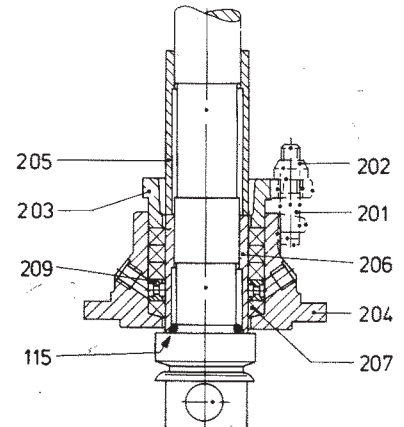

P13 Stuffing box with shaft wear sleeve and internal lantern ring.
P03 as P13, but without shaft wear sleeve ①.
 Suitable for abrasive pumped liquids with external liquid sealing $p = \text{up to } 4.0 \text{ bar}$.

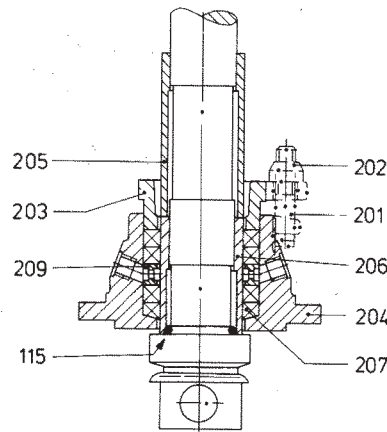

P14 Stuffing box with shaft wear sleeve and external lantern ring.
P04 as P14, but without shaft wear sleeve ①.
 For use where external sealing liquid incompatible with pumped liquid.
 $p = \text{up to } 3.0 \text{ bar}$.

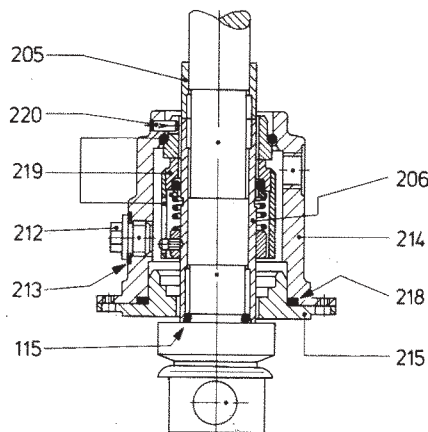

G04 as G17 Mechanical seal, single acting, non-balanced, either direction of rotation, with shaft wear sleeve and throttled outlet for seal liquid into pump chamber (type G16 shown in drawing).
G04 to G07 as G14 to G17, but without shaft wear sleeve ①.
 $p = \text{up to } 10 \text{ bar}$. Consult manufacturer.

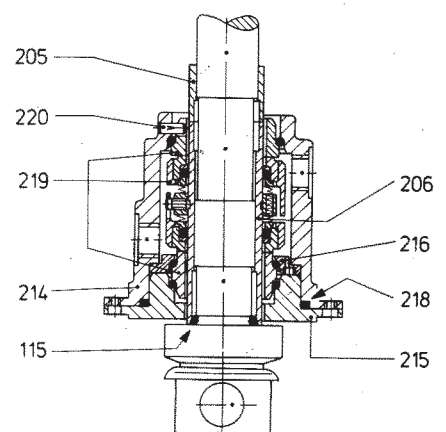

G18 as G19 Mechanical seal, double acting, non-balanced, either direction of rotation, with shaft wear sleeve. (type G19 shown in drawing).
G08 and **G09** as G18 and G19 but without shaft wear sleeve ①.
 $p = \text{up to } 10 \text{ bar}$. Consult manufacturer.

Part No.	Description
306	Clamping band
307	Coupling rod
308	Cover sleeve
401	Rotor
402	Stator
502 ④	Screwed plug
503 ④	Sealing ring
504	Discharge casing
505	Suction cover
211	Discharge casing gasket
516 ④	Stator casing
517 ④	O-ring
518	Drain plug
519	Sealing compound
601	Name plate

Part No.	Description
602	Dome headed grooved pin
603	Instruction label for commissioning
605	Discharge label
609	Hexagon nut
610	Washer
611	Tie rod
617	Hexagon head bolt
618	Hexagon nut
619	Lock washer
620	Hexagon socket screw
626	Hexagon nut
628	Instruction label grease quantity controller

- ① Parts 115, 205 and 206 not fitted to the P0 and G0 types (without shaft wear sleeve special execution).
- ② Only fitted to types G02, G03, G06, G07, G09, G12, G13, G16, G17 and G19.
- ③ Only with stainless steel versions (with other materials, available against extra charge).
- ④ Only fitted to types G10 to G13 and G00 to G03.
- ⑤ Only fitted to types P01 to P04, P11 to P14, G04 to G09 and G14 to G19.

Pump dimensions

Dimensions in mm. Internal diameter of ANSI flanges (DN) and threaded connections in inches. The manufacturers reserve the right to make technical modifications without prior notice.

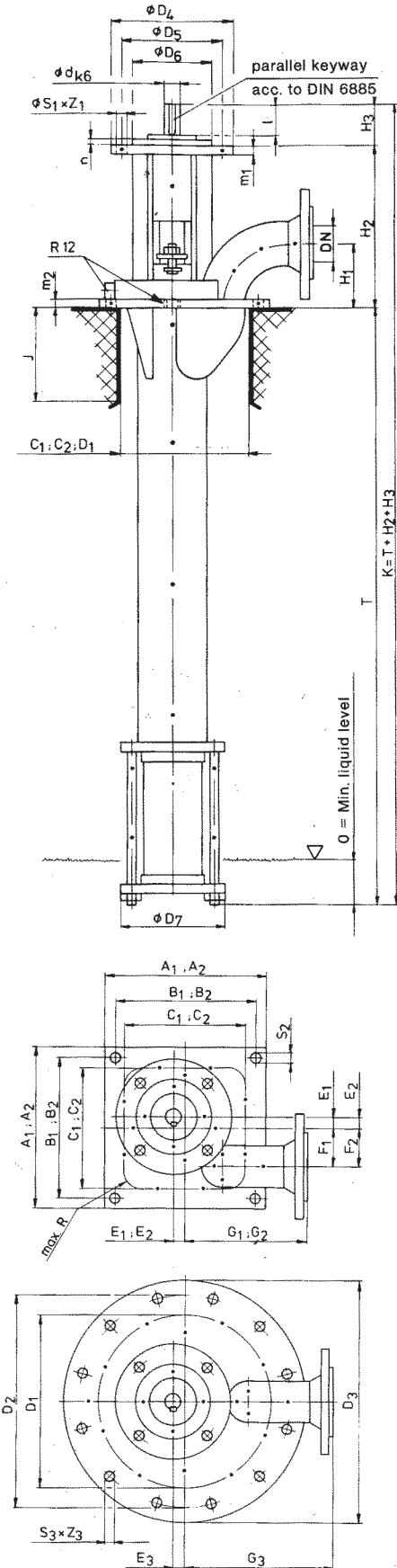

Mating dimensions for delivery connection DIN 2633, PN 16

Size					for mounting flange		
	DN	k ₁	d ₁	z	standard, squared G ₁	small, squared G ₂	circular G ₃
50.1	50	125	18	4	188	173	236 ①
50.2	50	125	18	4	188	173	236 ①
100.1	65	145	18	4	225	205	245 ②
100.2	65	145	18	4	225	205	245 ②
200.1	80	160	18	8	265	240	265
200.2	80	160	18	8	265	240	265
380.1	100	180	18	8	315	285	310
380.2	100	180	18	8	315	285	310
550.1	100	180	18	8	315	285	310
750.1	125	210	18	8	386	346	411 ③
750.2	125	210	18	8	386	346	411 ③
1000.1	125	210	18	8	386	346	411 ③
1450.1	150	240	22	8	451	401	436
1450.2	150	240	22	8	451	401	436
2700.1	200	295	22	12	567	497	540
5000.1	250	355	26	12	693	603	654
9500.1	300	410	26	12			

Mating dimensions for delivery connection ANSI B 16.5, class 150

Size					for mounting flange		
	DN	k ₁	d ₁	z	standard, squared G ₁	small, squared G ₂	circular G ₃
50.1	2	120,6	19	4	207	192	236 ④
50.2	2	120,6	19	4	207	192	236 ④
100.1	2 1/2	139,7	19	4	250	230	270 ⑤
100.2	2 1/2	139,7	19	4	250	230	270 ⑤
200.1	3	152,4	19	4	285	260	285
200.2	3	152,4	19	4	285	260	285
380.1	4	190,2	19	8	339	309	334
380.2	4	190,5	19	8	339	309	334
550.1	4	190,5	19	8	339	309	334
750.1	5	215,9	22,2	8	420	380	445 ⑥
750.2	5	215,9	22,2	8	420	380	445 ⑥
1000.1	5	215,9	22,2	8	420	380	445 ⑥
1450.1	6	241,3	22,2	8	485	435	470
1450.2	6	241,3	22,2	8	485	435	470
2700.1	8	298,4	22,2	8	607	537	580
5000.1	10	361,9	25,4	12	725	635	686
9500.1	12	431,8	25,4	12			

- ① min D₁ = 200, G₃ = 184
 - ② min D₁ = 250, G₃ = 220
 - ③ min D₁ = 450, G₃ = 386
 - ④ min D₁ = 200, G₃ = 203
 - ⑤ min D₁ = 250, G₃ = 245
 - ⑥ min D₁ = 450, G₃ = 420
- circular mounting flanges.
Also available in smaller dimensions.
For dimensions (e.g. D₁) see page 9.

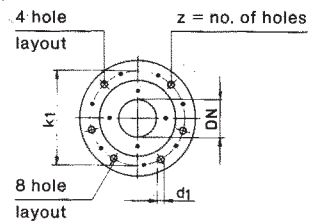
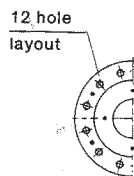

Z₁, Z₂, Z₃ = no. of holes

Direction of rotation: clockwise looking from the drive end is standard

		Pump size																	
		50.1	50.2	100.1	100.2	200.1	200.2	380.1	380.2	550.1	750.1	750.2	1000.1	1450.1	1450.2	2700.1	5000.1	9500.1	
Pump dimensions	D ₄	160	160	200	200	250	250	250	250	250	300	300	300	350	350	400	400		
	D ₅	130	130	165	165	215	215	215	215	215	265	265	265	300	300	350	350		
	D ₆	110	110	130	130	180	180	180	180	180	230	230	230	250	250	300	300		
	D ₇	135	135	150	150	180	180	215	215	215	270	270	270	320	320	375	455		
	H ₁	82	82	107	107	127	127	155	155	155	196	196	196	231	231	325	398		
	H ₂	219	219	255	255	287	287	321	321	321	384	384	384	438	438	521	402		
	H ₃	52	52	58	58	73	73	85	85	85	99	99	99	122	122	145	129		
	J	120	120	150	150	180	180	220	220	220	270	270	270	320	320	440	540		
	d	20	20	22	22	28	28	35	35	35	42	42	42	55	55	70	75		
	l	45	45	50	50	65	65	75	75	75	90	90	90	110	110	130	125		
	m ₁	11	11	11	11	11	11	11	11	11	11	11	11	15	15	15	15		
	m ₂	10	10	12	12	12	12	12	12	12	15	15	15	15	15	20	20		
	n	4	4	4	4	4	4	4	4	4	4	4	4	5	5	5	5		
	o	20	20	20	20	25	25	25	25	25	30	30	30	30	30	40	50		
	S ₁	9	9	11	11	13,5	13,5	13,5	13,5	13,5	13,5	13,5	13,5	17,5	17,5	17,5	17,5		
Z ₁	4	4	4	4	4	4	4	4	4	4	4	4	4	4	4	4			
R12 ⑤	R _p 3/8	R _p 3/8	R _p 1/2	R _p 1/2	R _p 1/2	R _p 1/2	R _p 3/4	R _p 3/4	R _p 3/4	R _p 3/4	R _p 3/4	R _p 3/4	R _p 3/4	R _p 3/4	R _p 1	R _p 1			
Standard installations ⑥ depths	T	640	800	600	800														
		1040	1200	1000	1200	948	1200	894	1200	1048									
		1440	1600	1400	1600	1348	1600	1294	1600	1448	1200	1600	1312			1600			
		1840	2000	1800	2000	1748	2000	1694	2000	1848	1600	2000	1712	1495	2000	2000	2000		
				2200	2400	2148	2400	2094	2400	2248	2000	2400	2112	1895	2400	2400	2400		
						2548	2800	2494	2800	2648	2400	2800	2512	2295	2800	2800	2800		
								2894	3200	3048	2800	3200	2912	2695	3200	3200	3200		
												3200	3600	3312	3095	3600	3600	3600	
Mounting flanges ④ ⑦	standard, squared	A ₁	270	270	320	320	380	380	440	440	440	540	540	540	640	640	750	900	
		B ₁	240	240	280	280	340	340	400	400	400	495	495	495	590	590	700	840	
		C ₁	210	210	250	250	300	300	360	360	360	450	450	450	540	540	640	780	
		E ₁	0	0	0	0	0	0	0	0	0	0	0	0	0	0	0	0	
		F ₁	71	71	85	85	100	100	120	120	120	150	150	150	180	180	200	245	
		R	30	30	35	35	45	45	55	55	55	70	70	70	90	90	110	140	
		S ₂	14	14	18	18	18	18	18	18	18	23	23	23	23	23	27	27	
		small, squared	A ₂	240	240	280	280	330	330	380	380	380	460	460	460	540	540	610	720
			B ₂	210	210	240	240	290	290	340	340	340	415	415	415	490	490	560	660
	C ₂		180	180	210	210	250	250	300	300	300	370	370	370	440	440	500	600	
	E ₂		15	15	20	20	25	25	30	30	30	40	40	40	50	50	70	90	
	F ₂		56	56	65	65	75	75	90	90	90	110	110	110	130	130	130	155	
	R		30	30	35	35	45	45	55	55	55	70	70	70	90	90	110	140	
	S ₂		14	14	18	18	18	18	18	18	18	23	23	23	23	23	27	27	
	circular ⑦		D ₁	300 ①	300 ①	300 ②	300 ②	300	300	350	350	350	500 ③	500 ③	500 ③	600	600	600	700
			D ₂	375	375	375	375	375	375	420	420	420	560	560	560	665	665	665	765
		D ₃	415	415	415	415	415	415	460	460	460	600	600	600	710	710	710	810	
		E ₃	0	0	15	15	41	41	55	55	55	37	37	37	90	90	110	140	
S ₃		18	18	18	18	18	18	18	18	18	18	18	18	23	23	23	23		
Z ₃		12	12	12	12	12	12	16	16	16	20	20	20	24	24	24	28		

① min D₁ = 200, E₃ = 33
 ② min D₁ = 250, E₃ = 40
 ③ min D₁ = 450, E₃ = 62
 ④ Contact surface not machined
 ⑤ Pipe thread acc. to DIN 2999
 ⑥ Alternative installation depths possible (consult manufacturer)
 ⑦ Mating dimensions acc. to DIN 28 034
 ⑧ Larger mounting flanges possible (consult manufacturer)
 circular mounting flanges. Also available in smaller dimensions.
 For remaining mounting flange versions see ⑧

Auxiliary connections

Positions of auxiliary connections

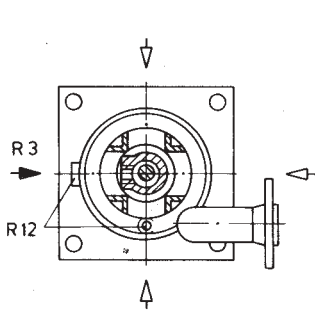

Stuffing boxes P12 and P02

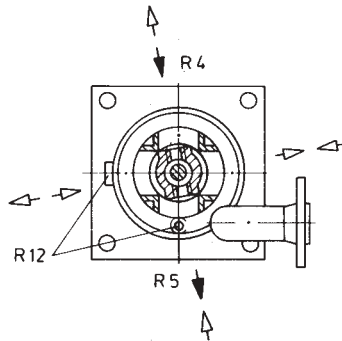

Stuffing boxes P13 and P03

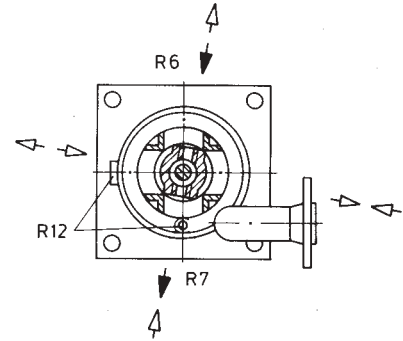

Stuffing boxes P14 and P04

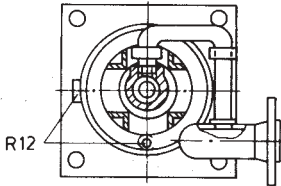

Mechanical seals G10 to G13 and G00 to G03

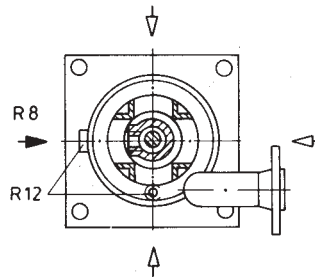

Mechanical seals G14 to G17 and G04 to G07

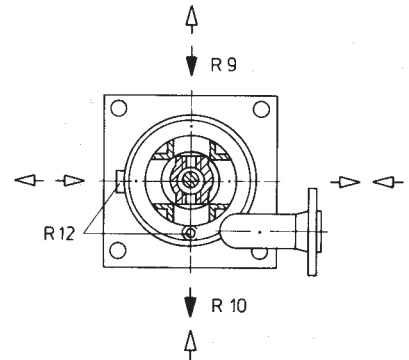

Mechanical seals G18 to G19 and G08 and G09

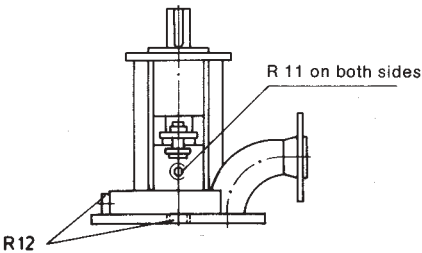

Auxiliary connections where jacket fitted for heating or cooling.
Heating or cooling liquid:
max. permissible pressure 10 bar,
max. permissible temperature 180 °C.

▲ standard flow direction
△ alternativ flow direction

Sizes of auxiliary connections

Size	Flushing connections		Gland seal connections			Heating/cooling connections	Drain connection
	R3	R8 ①	R4/R5 ①	R6/R7 ①	R9/R10 ①		
50.1	M 8x1 ②	G 1/4	G 1/8	G 1/8	G 1/4	R _p 1/8	R _p 3/8
50.2	M 8x1 ②	G 1/4	G 1/8	G 1/8	G 1/4	R _p 1/8	R _p 3/8
100.1	G 1/8 ①	G 1/4	G 1/8	G 1/8	G 1/4	R _p 1/8	R _p 1/2
100.2	G 1/8 ①	G 1/4	G 1/8	G 1/8	G 1/4	R _p 1/8	R _p 1/2
200.1	G 1/8 ①	G 3/8	G 1/8	G 1/8	G 3/8	R _p 1/4	R _p 1/2
200.2	G 1/8 ①	G 3/8	G 1/8	G 1/8	G 3/8	R _p 1/4	R _p 1/2
380.1	G 1/8 ①	G 1/2	G 1/8	G 1/8	G 1/2	R _p 1/4	R _p 3/4
380.2	G 1/8 ①	G 1/2	G 1/8	G 1/8	G 1/2	R _p 1/4	R _p 3/4
550.1	G 1/8 ①	G 1/2	G 1/8	G 1/8	G 1/2	R _p 1/4	R _p 3/4
750.1	G 1/4 ①	G 1/2	G 1/4	G 1/4	G 1/2	R _p 3/8	R _p 3/4
750.2	G 1/4 ①	G 1/2	G 1/4	G 1/4	G 1/2	R _p 3/8	R _p 3/4
1000.1	G 1/4 ①	G 1/2	G 1/4	G 1/4	G 1/2	R _p 3/8	R _p 3/4
1450.1	G 1/4 ①	G 1/2	G 1/4	G 1/4	G 1/2	R _p 3/8	R _p 3/4
1450.2	G 1/4 ①	G 1/2	G 1/4	G 1/4	G 1/2	R _p 3/8	R _p 3/4
2700.1	G 1/4 ①	G 1/2	G 3/8	G 3/8	G 1/2	R _p 3/8	R _p 1
5000.1	G 1/4 ①	G 1/4	G 1/4	G 1/4	G 1/2	R _p 3/8	R _p 1
9500.1							

- ① Pipe thread acc. to DIN ISO 228, Part 1
- ② Metric fine thread acc. to DIN 13
- ③ Pipe thread acc. to DIN 2999.

Tappings for pressure gages can be provided, if required, at extra cost.

Auxiliary connections R3 to R12 can also be supplied with NPT threads (same i.D.).

Weights, possible drive arrangements

Weights

		Pump size																
		50.1	50.2	100.1	100.2	200.1	200.2	380.1	380.2	550.1	750.1	750.2	1000.1	1450.1	1450.2	2700.1	5000.1	9500.1
Weights	kg	T = 1000 mm, mounting flange, standard, squared																
	kg	T = 1000 mm, mounting flange, small, squared																
	kg	T = 1000 mm, mounting flange, circular																
	kg	Extension per 1000 mm																

Possible drive arrangements

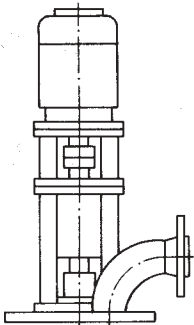

1 SETP with flexible coupling and electric motor

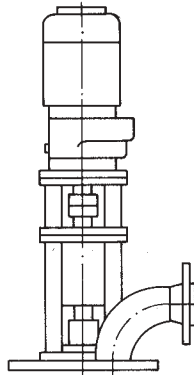

2 SETP with flexible coupling and geared motor

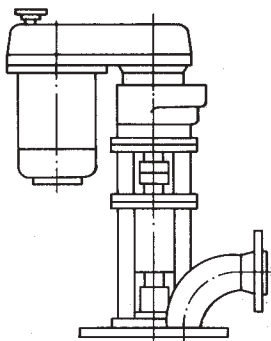

3 SETP with flexible coupling and infinitely variable speed gear

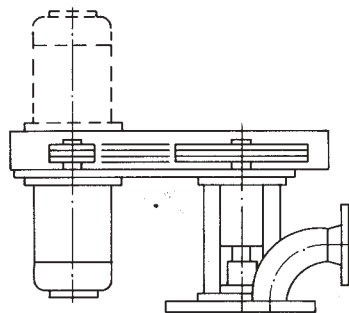

4 SETP with V-belt drive and electric motor. Consult manufacturers

Range of eccentric screw pumps	Series	Number of stages	Maximum output at $\Delta p = 0$ bar		Maximum del. pressure bar	Maximum viscosity mPa·s
			m ³ /h	l/min		
	AE.E-ID	1,2	450	7500	10	300.000
	AE.N-ID	1,2	290	4850	12	270.000
	AED.E-ID	1	720	12000	8	250.000
	AE.N...-RG	1,2,4	21	350	20	1.000.000
	AED.N-ID	2	450	7500	16	225.000
	SLBP	1	90	1500	5	75.000
	SEBP	1,2	174	2900	6	300.000
	SEDBP	1	258	4300	6	250.000
	SEZP	1,2	21	350	10	1.000.000
	SNBP	1,2	111	1850	12	300.000
	SNDBP	2	174	2900	12	225.000
	SHP	2,4	110	1830	24	270.000
	SHBP	4	29	490	24	85.000
	SNZP	1,2	45	750	12	1.000.000
	SNZBP	1,2	45	750	12	1.000.000
	SSP	1,2	48	800	12	150.000
	SSBP	1,2	48	800	12	150.000
	SETP [®]	1,2	140	2350	10	300.000
	SETBP	1,2	40	670	10	150.000
	SEFBP	1	40	670	6	150.000
	SMP	1	40	670	6	150.000
	SMP2	1	5,5	92	6	11.500
	AFP	1	2,8	47	6	50.000
	ANP	2	2,5	42	12	20.000
	ANBP	2	2,5	42	12	20.000
	ASP	2	2,5	42	12	20.000
	ASBP	2	2,5	42	12	20.000
	ADP	3	0,6	10	12	20.000
	ADBP	3	0,6	10	12	20.000
	ACNP	1,2	29	480	12	150.000
	ACNBP	1,2	29	480	12	150.000

© Special versions for higher pressures available.

Peristaltic range

Series	Maximum output		Maximum del. pressure bar	Maximum viscosity mPa·s
	m ³ /h	l/min		
ASL	2,4	40	4	100.000
ASH	60	1000	15	100.000

Macerator range

Series	Maximum throughput m ³ /h	Generated delivery head m
AM...S-1	80 at 3% solids	3
ABM...S-1	80 at 3% solids	3
AM...I-1	160 at 3% solids	-
ABM...I-1	80 at 3% solids	-

Accessories

Pump accessories: Stator setting devices, electrical heaters, bridge breakers.

Drivers: Electric motors, geared motors, variable speed transmissions, reduction gearboxes, internal combustion engines, pneumatic and hydraulic drives.

Transmission components: Couplings, V-belt transmissions, toothed belt transmissions, other types of transmission.

Base plates: Standard and special versions, wheeled trolleys, mounting flanges.

Safety arrangements: Bypass lines with safety or regulating valves, systems to guard against dry running (conductive, capacitive, thermal etc.).

Other accessories: Electrical, hydraulic and pneumatic control arrangements, filter systems, metering equipment, seal liquid and circulating systems for shaft seals, valves, flanges, flexible pipes.

Subject to technical alterations.

ALLWEILER AG

Werk Bottrop

Postfach 200123
D-46223 Bottrop
Kirchhellener Ring 77-79
D-46244 Bottrop
Germany
Phone +49 2045 966-60
Fax +49 2045 966-679
Internet: <http://www.allweiler.de>

The stated performance data are to be understood only as an outline of performance of our products. For exact limits of application please refer to the quotation and acceptance of order.